



COUVERCLE DE CONNECTEUR

Notice 2F - Rév. : 2



MARECHAL ELECTRIC S.A.
5, avenue de Presles
F-94417 Saint-Maurice Cedex - France
Tél. : +33 (0) 1 45 11 60 00
Fax : +33 (0) 1 45 11 60 60
e-mail : mail@marechal.fr
www.marechal-electric.com

CE KIT CONTIENT :

- Un joint plat
- Quatre vis auto-taraudeuses à pas large pour accessoires arrières plastique
- Quatre vis auto-taraudeuses à pas fin pour accessoires arrières métal
- Un couvercle de connecteur à rappel automatique

INSTRUCTIONS DE MONTAGE

Procéder au montage comme suit, en respectant l'orientation du connecteur et du couvercle :

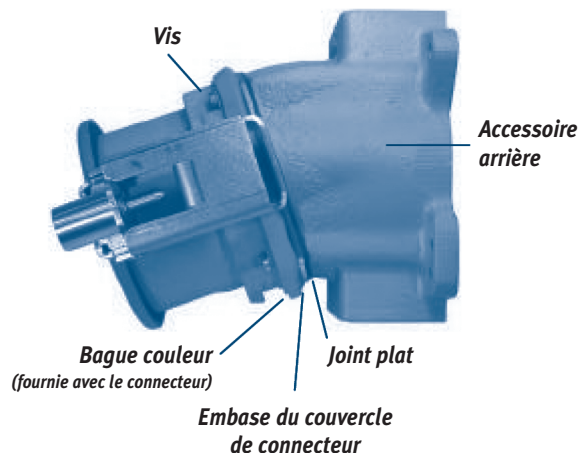

OPTION VERROUILLAGE (pour le DS9 uniquement)

Serrer la vis de verrouillage à fond pour assurer l'étanchéité IP X5.

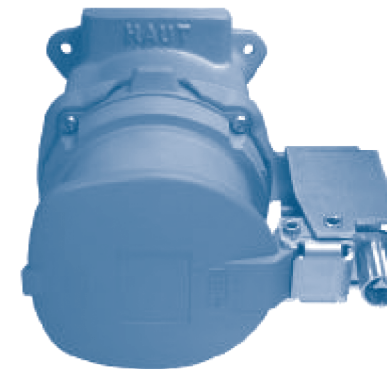

MARECHAL ELECTRIC est membre de l'association internationale des fabricants de connecteurs électriques à contacts en bout BECMA.





INLET COVER

N. 2A - Rev. : 2



MARECHAL ELECTRIC S.A.
 5, avenue de Presles
 F-94417 Saint-Maurice Cedex - France
 Tél. : +33 (0) 1 45 11 60 00
 Fax : +33 (0) 1 45 11 60 60
 e-mail : mail@marechal.fr
 www.marechal-electric.com

A manufacturer of products bearing the  Quality Label

THIS KIT INCLUDES

- One flat gasket
- Four large-pitched self-tapping screws for polymeric rear accessories
- Four thin-pitched self-tapping screws for metal rear accessories
- One self-closing inlet cover

ASSEMBLY INSTRUCTIONS

Assemble as per the following sketch. Respect inlet and cover hinge orientation :

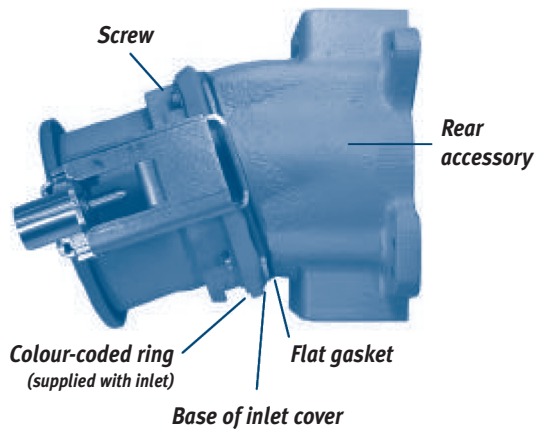

OPTIONAL LOCKING (for DS9 only)

Tighten the locking screw right home to perform ingress protection IP X5.

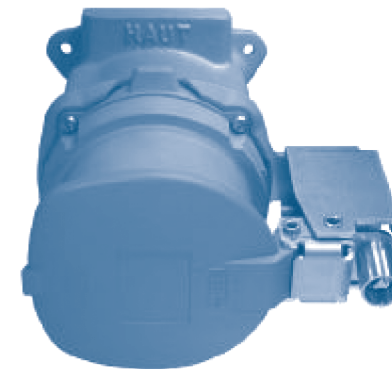

MARECHAL ELECTRIC is a member of the international association, BECMA : the Butt-contact Electrical Connectors Manufacturers' Association.



www.becma.ch